



BRADNAM'S

AWNING
WINDOWS



Bradnam's
windows & doors

Awning Window Range

If you want windows that can provide natural ventilation year-round and invite natural light into your home, Bradnam's **awning windows** are exactly what you've been looking for.

Essential Awning Windows

'Essential' awning windows are our standard aluminium awning window product. Packed full of benefits and features, they've been designed with modern living in every Australian climate firmly in mind. Our Essential awning windows are available in a range of standard configurations as well as custom designs.

Signature Awning Windows

Our 'Signature' awning window range is a high quality collection that includes both standard and oversize options, so you can find the perfect window to suit your home's design and aspect. They can be combined with other Bradnam's windows to create feature windows or maximise natural light and your view.

Commercial Awning Windows

Bradnam's 'Commercial' collection includes aluminium awning windows in small and large sizes. Aesthetically appealing and heavy duty, they're specifically designed for commercial environments or unique, high end homes.

Performance Parameters

	Essential	Signature	Commercial
Frame size	52mm	100mm	100mm
Maximum panel height	2400mm	2400mm	2400mm
Maximum panel width	2150mm	2150mm	2150mm
Maximum panel weight	74kg	74kg	74kg
Maximum water rating	600Pa	600Pa	600Pa
Maximum wind rating	4500Pa ULS	4500Pa ULS	4500Pa ULS
Maximum glass thickness (single glazed)	12.76mm	12.76mm	12.76mm
Maximum glass thickness (double glazed)	24mm	24mm	24mm
Maximum acoustic rating	Rw37	Rw38	N/A
Maximum bushfire rating	BAL 40	BAL 40	BAL 40
Lowest U-value (single glazed)	5.0	5.5	N/A
Lowest U-value (double glazed)	3.3	3.8	N/A

Features & Benefits

Essential . Signature . Commercial

Lifestyle & Comfort

- Natural ventilation year-round, with a top hinged design that allows air-flow even during light rain showers
- Safe design with no exposed sharp edges reducing the chance of injury

Optional

- Opening restrictions for improved safety of upper storey windows
- Curtain-friendly folding handles limit interference with window furnishings

Design & Aesthetic

- Architectural symmetry with other Bradnam's windows and doors for a holistic look and feel
- 'Picture frame' look created with improved mitre joints

Optional

- Security and insect screens installed within the frame allow easy access to the window

Performance & Reliability

- Greater stability with sashes hung from a concealed heavy duty bar
- Minimum corrosion with stainless steel chains
- Long-lasting santoprene seals provide superior protection against harsh Australian weather conditions
- Thermal and acoustic insulation, with various glazing options including single and double glazing

Optional

- Twin chains allow for easy operation of large sashes

+ Premium Features

Signature & Commercial Only

- Feature window potential when combined with fixed lites
- Oversize windows available
- Superior strength and integrity with 100mm aluminium frame width

Commercial Only

- Internal glazing system – ideal for multi-storey projects



Smart Solutions

High Performance Windows and Doors

Essential . Signature . Commercial

Building in today's environment demands the need to satisfy energy, acoustics, security and bushfire requirements. Bradnam's **Smart Solutions** range is designed to augment all Essential, Signature and Commercial products to satisfy these needs.

Some of the possible benefits

- Cooler in Summer
- Warmer in Winter
- Enhanced UV protection
- Minimise noise outside
- Save on energy bills
- Added security

Performance comes from **more than just glass**

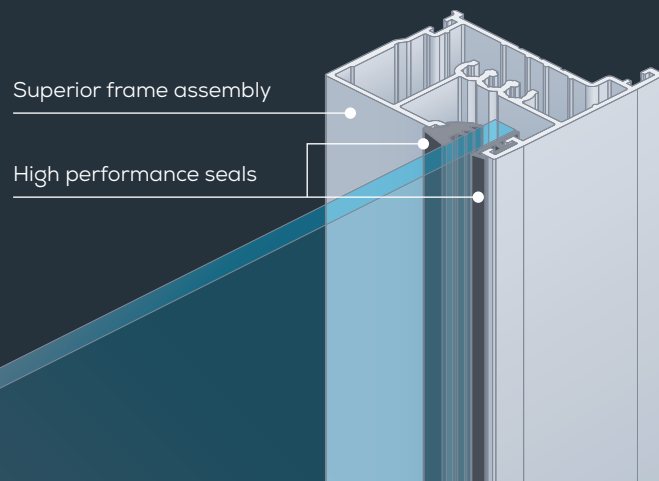

As the market leader in Australia for aluminium and glass building products, Bradnam's have developed its range of **Smart Solutions** to meet all high performance requirements.

+ Premium Smart Solution

Double Glazed

Year-round Comfort

- Acts as extra insulation by limiting the flow of hot or cold air in and out of your home
- Helps maintain comfortable temperatures inside across all seasons

Energy Reduction

- Reduce reliance on air conditioning and heaters – lowering electricity bills
- Consume less energy for a smaller carbon footprint

Noise Reduction

- Minimise outside noise – creating a quiet haven inside your home

Safety

- Extra strong resistance to unwanted attacks by intruders

Climate Control Solutions

Solar Comfort™

Year-round Comfort

- Designed to reflect heat away in summer and keep heat inside during winter
- Enjoy the ideal temperature in your home all year round – cooler in summer, warmer in winter

Energy Reduction

- Keep power bills down by reducing the need for additional heating and cooling
- Help save the environment by consuming less energy

Solar Block™

Cooler in Summer

- Minimise the flow of heat into your home – enjoy summer without feeling the heat
- Acts like a pair of sunglasses for your home, reducing glare by up to 78%

Energy Reduction

- Save on electricity bills by reducing the need for air conditioners
- Minimise your carbon footprint by consuming less energy

Specialty Solutions

Safety

Safety

- Effective, affordable barrier against forced entry
- Enjoy peace of mind knowing that your home has extra protection

Sound Smart™

Noise Reduction

- Reduce unwanted external noise – nearby traffic or noisy neighbours,

FlameShield™

Superior Bushfire Protection

- Meets Australian Standard AS3959:2009, which is aimed to reduce the risk of loss of life and property in bushfire prone areas

AWNING WINDOWS

Essential . Signature . Commercial



Hardware

The hardware displayed on this page are a guide only. Bradnam's recommend the viewing of an actual hardware product prior to order.

	Black Matt	Black Gloss	White	Ultra Silver	Designer Silver	Stainless Steel Finish
ESSENTIAL		•	•	•	•	
SIGNATURE		•	•	•	•	
COMMERCIAL		•	•	•	•	

ESSENTIAL SIGNATURE COMMERCIAL

Handles can be folded to minimise interference with window furnishings

Single chain winder

Optional folding handle

Twin chain winder

Standard folding handle

Single chain winder

Twin chain winder

Optional sash catch for improved weather proofing

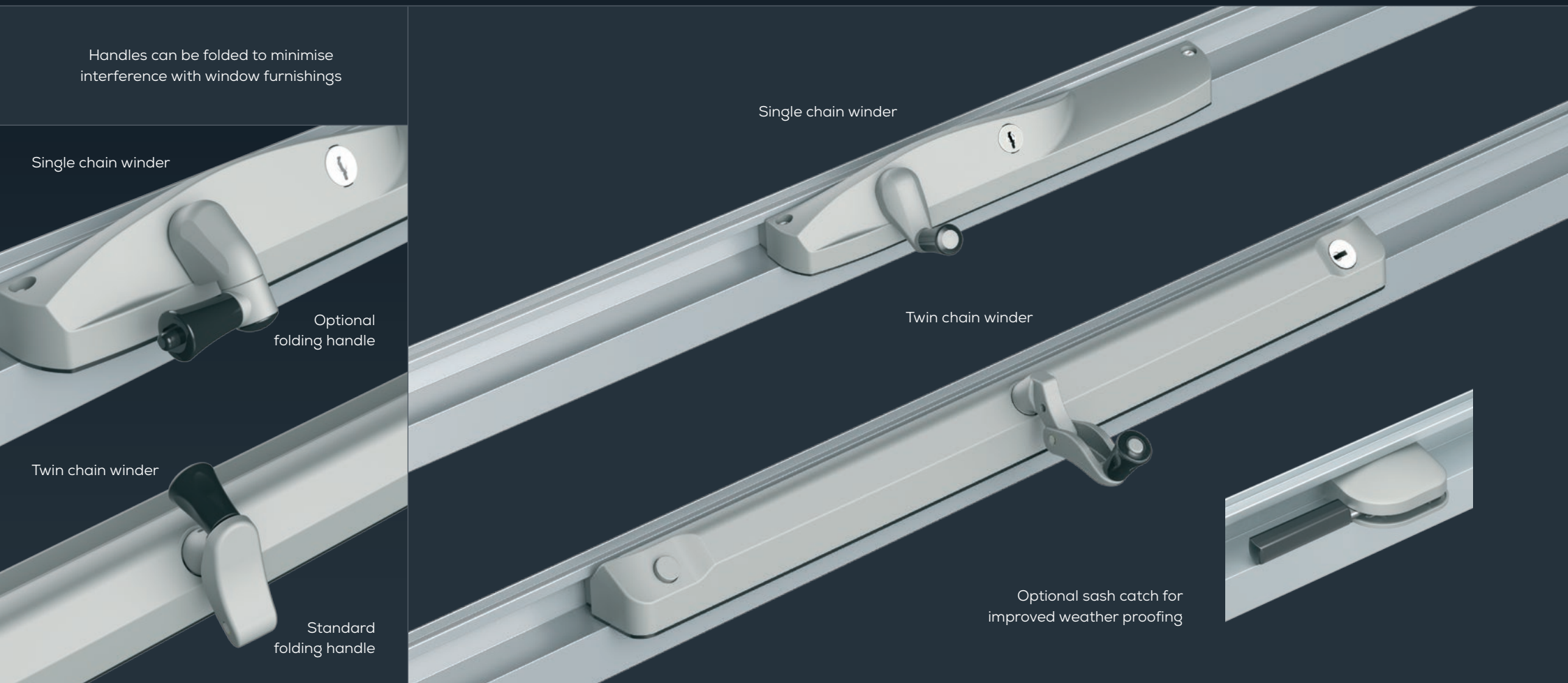



For more information call Bradnam's on
1300 WINDOWS 1300 946369
or visit bradnams.com.au

WINDOWS & DOORS

INSECT & SAFETY SCREENS

SHOWER SCREENS

MIRRORS & WARDROBES

SPLASHBACKS & SHELVING



Australian
Owned & Made

Bradnam's products are proudly made
in Australia and designed specifically
to meet all Australian conditions

Note: Products may be subject to local
variation, regulatory requirements and
confirmation of structural performance



Bradnam's
windows & doors

Bradnam's Windows and Doors . QBCC Act lic 58885
© Bradnam's Windows and Doors Oct 2016